

**The most used gate of the World Cup ski teams**



**SETTELE SPORTSYSTEMS**  
**START GATE FIS EVO**

**24V**

**Parallel event**  
**Team event**  
**Random start**

**MANUAL**

**15.01.2026**

## Assembly instruction

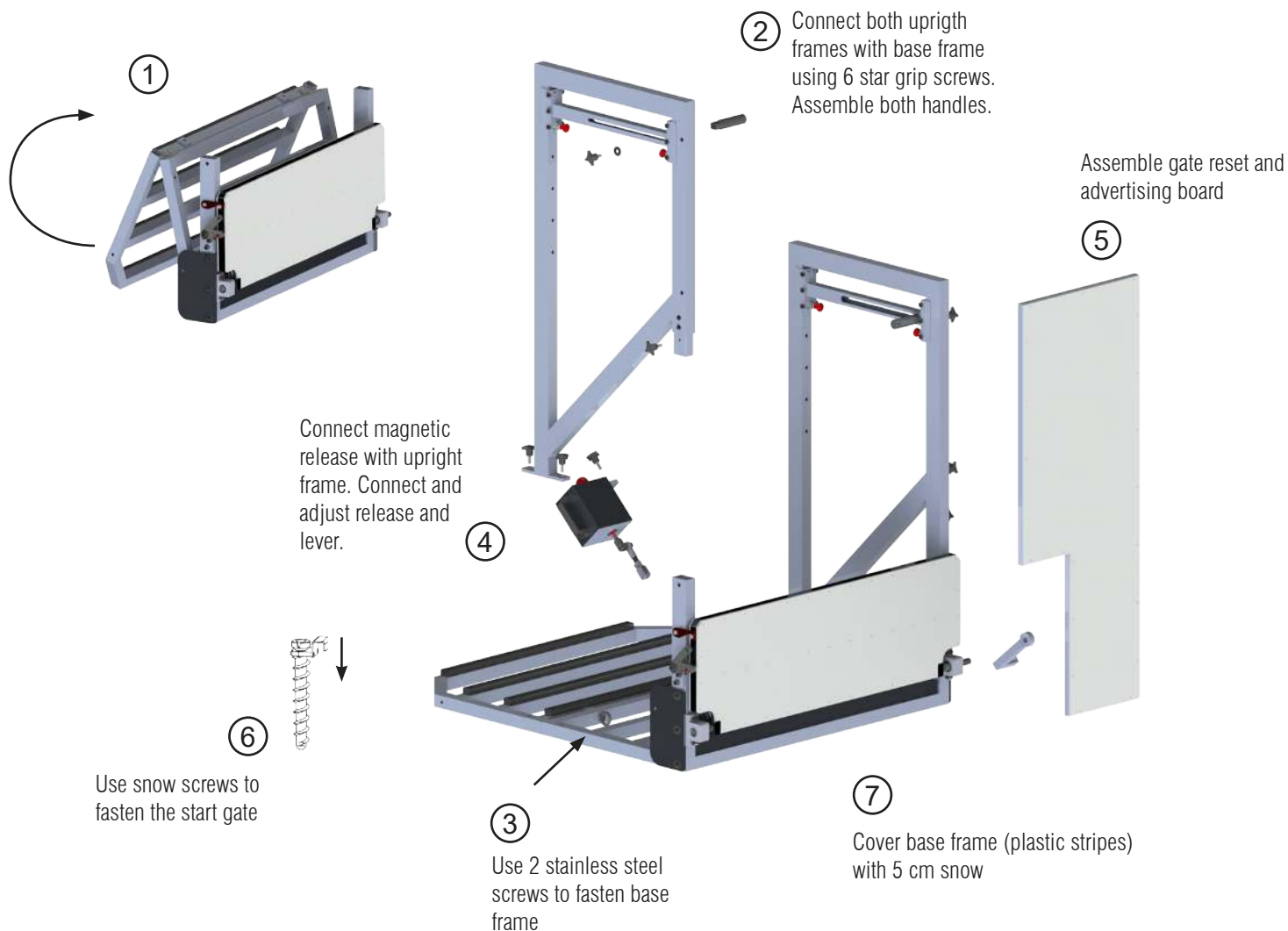

## START GATE FIS EVO

The competition and training gate  
 The Start Gate FIS is made of aluminium. This makes the system stable and particularly light weight. The start gate consists of a single launch site. On the one hand it is intended as a training facility for winter and summer and on the other hand for parallel and team competitions as a light weight alternative to the Start Gate WC.

Incomplicated transport and assembly  
 The Start Gate FIS is almost completely assembled from the start. It can be assembled and disassembled easily in just a few steps. Due to its low weight, transport is easy and comfortable. In addition, the gate can simply be folded together and stowed in the transport bag.

Trigger  
 The start can be triggered manually or electronically. Together with our electronic control systems it forms a complete setup for competition and training measures. Through the use of the random system it is for example also possible to trigger the start signal in the training itself. Thus an optimal start training can be completed.

## Electronic setup

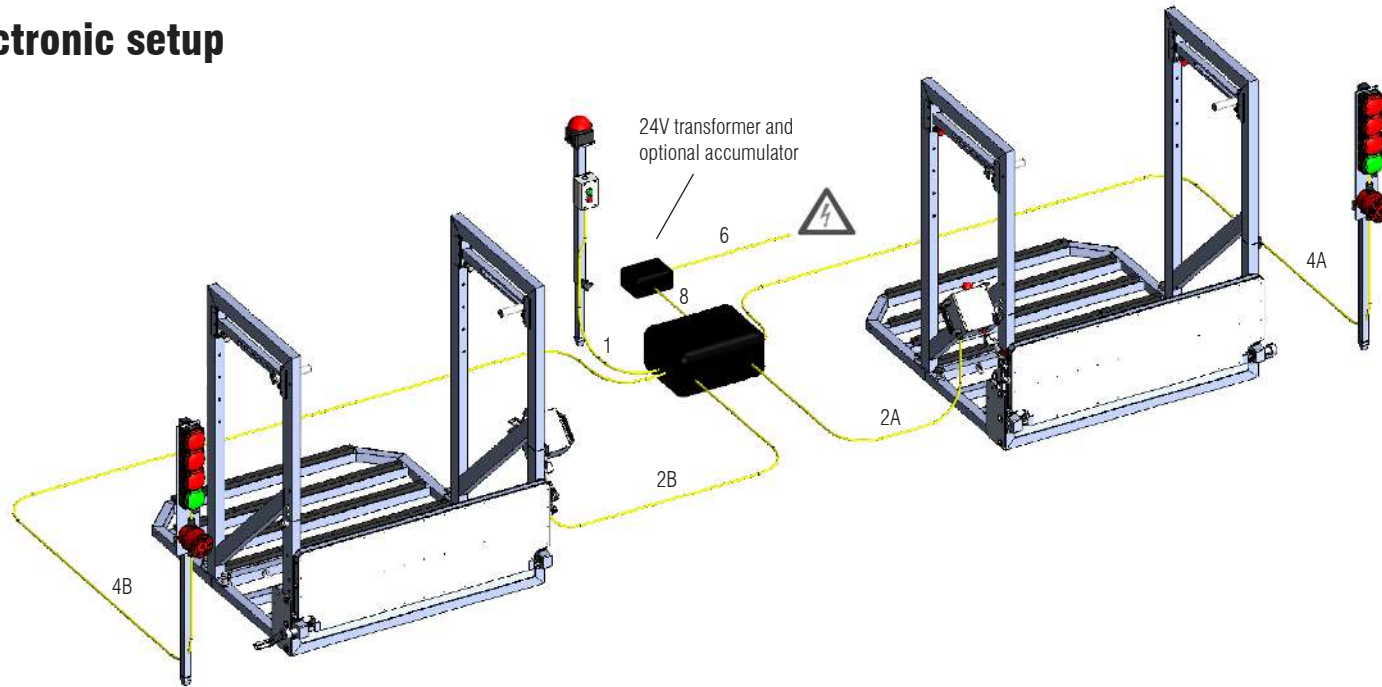

**Start buzzer**  
 cable number 1



**Control unit and 24V transformer/opt accumulator**



**2x Signal light/ Acoustic horn**  
 cable number 4A  
 cable number 4B



**2x Magnetic release connection**  
 cable number 2A  
 cable number 2B



**Power connection**  
 cable number 6



## Control unit

**Signal light  
 Acoustic horn**  
 4A 4B

**Start buzzer**  
 1

**24V Transformator  
 Accumulator**  
 8

**Fuse**  
 Remove cap to reach  
 fuse

**Magnetic release**  
 2A 2B



**Setup touchscreen**  
 Setup for different race modi  
 Buttons F1-F4

**Output time measurement**  
 Provides the starting signal to your time measurement.  
 2 Gates: Red A and Blue B

**Input start impulse (Teamevent)**  
 Trigger for the second (and following) start impulse from the time measurement system at the team race format. This opens the gate for the next runner when the first runner crosses the finish line.

**Please note: the electronic parts cable number should be the same as the control socket number**  
 Example: Plug the Start buzzer connection (cable number 1) to the Start buzzer socket (number 1) on control unit

## Control unit and time measurement

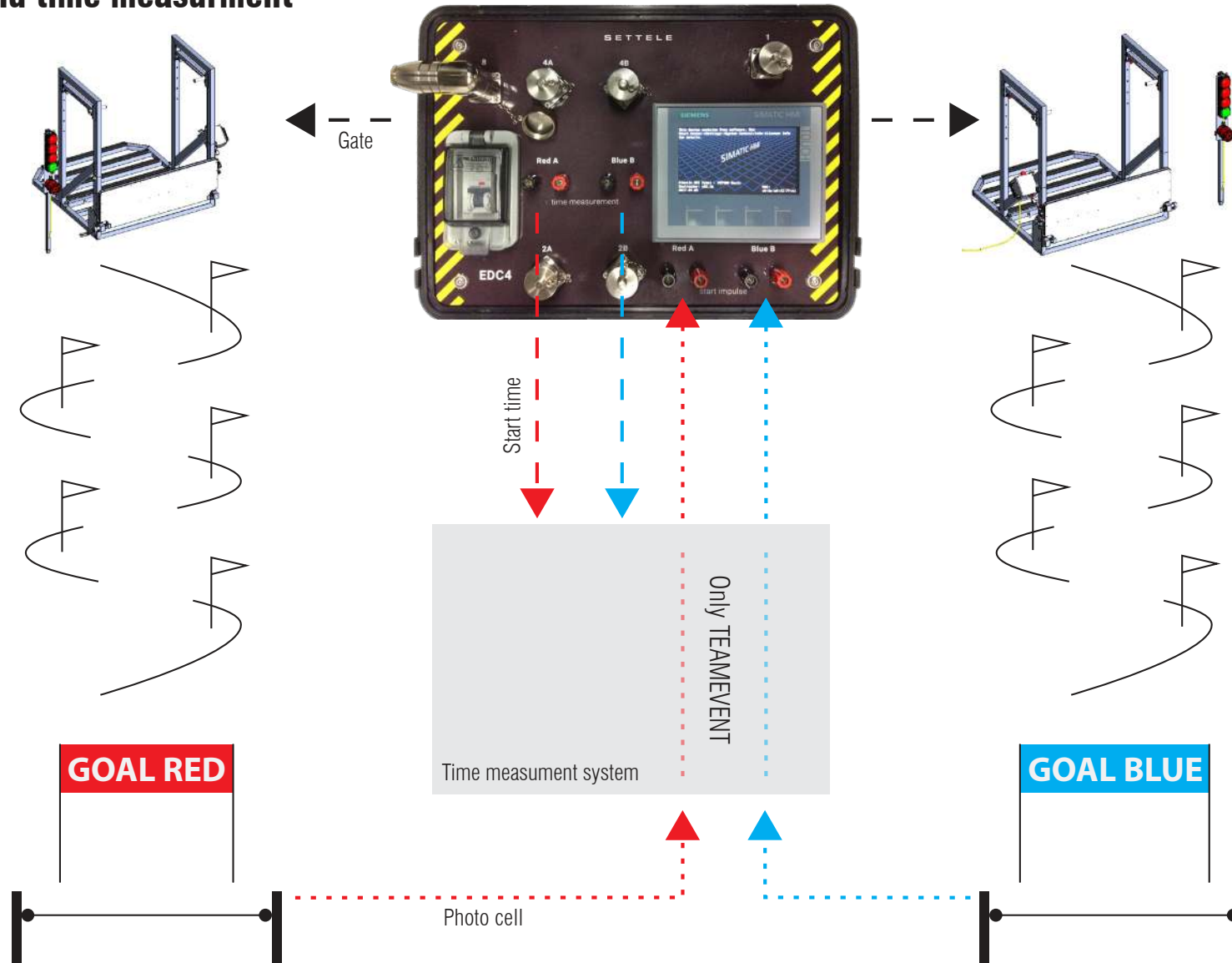

## Setup touchscreen

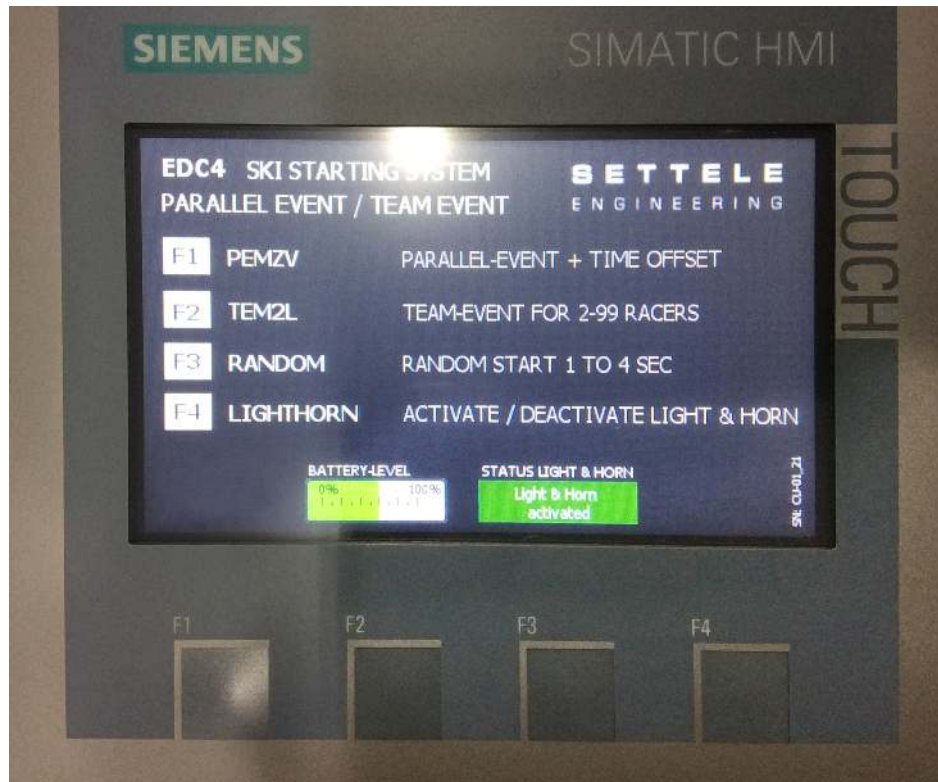

On plug the power the system will be startet. Wait about 15 seconds for the main screen to appear.

### Main screen

Select one of three different race modi:

#### 1. Parallelevent

Button F1 -> PEMZV (parallel-event with variable time offset)

#### 2. Teamevent

Button F2 -> TEM2L (team-event for 2 to 99 team racer)

#### 3. Random

Button F3 -> RANDOM (1 to 4 seconds delay)

#### Optional

Button F4 -> Start option with (without) horn/lights and count-down.

This option provides a 4 second countdown before opening the gates at the parallel- or teamevent. Without this option the gates will open immediately after pressing the start buzzer.

## Setup touchscreen



### Gate-Sensors:

If everything is wired correctly and the magnetic release is ready, this field turns green. The field turns gray (not active) if the magnetic release is blocked (e.g. through ice) or the wiring is wrong. And it shortly turns gray when the gates open.

### 1. Parallelevent - Main screen

The release for each gate can be set individually.

On touching the delay time button the input field will be opened for input the time offset (start red or start blue)

Button F3 -> reset (race will be aborted, time offset will be reseted)

Button F4 -> home - back to main screen

## Setup touchscreen



### 1. Parallelevent - Input time difference screen

You are able to edit a delay time up to 99999ms (nearly 100 seconds).

On touching the numbers the delay amount will be fed in.

Please use the enter symbol to adopt the delay time.

## Setup touchscreen



### 1. Parallelevent - Main screen

After pressing the enter symbol at the input time difference screen you will be send back to the parallelevent main screen with the adopted delay time.

In this example, pressing the start buzzer opens the blue gate after a countdown of 4 seconds (light and horn – is activated). The red gate opens with countdown on delay of 1 second.

To deactivate the countdown, press the F4 „Option“ key on the main screen of the control unit.

*To communicate the starting signal for your time measurement use the „output time measurment“ contact at the control unit.*

## Setup touchscreen

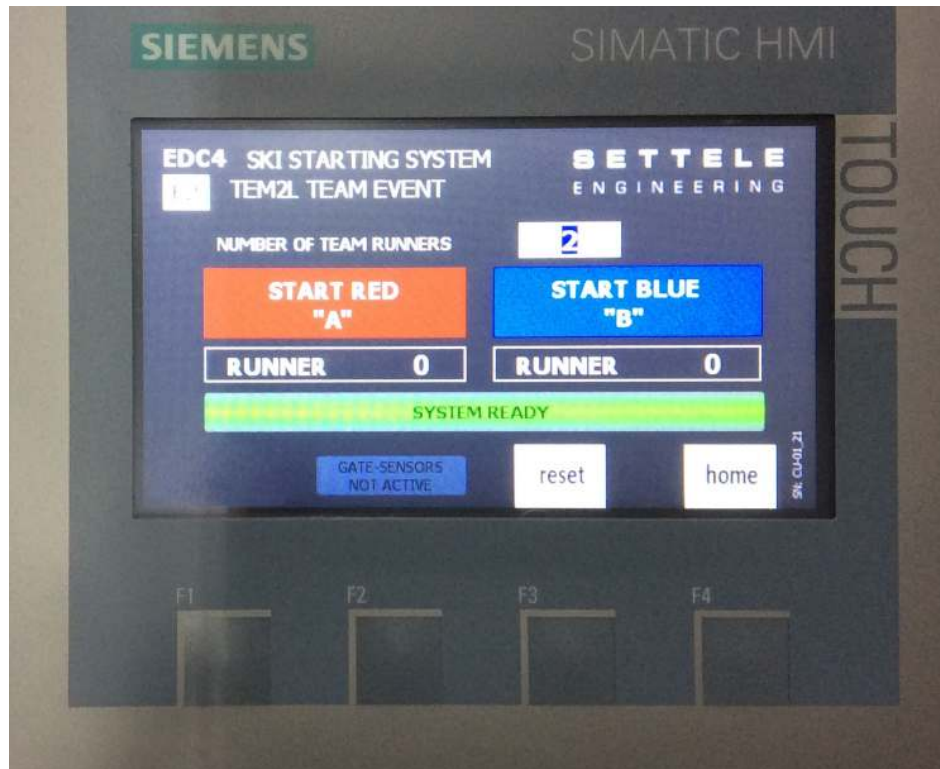

### 2. Teamevent - Main screen

On touching the number field of „number of team runners“ the input field will be opened for choose the number of team runners. You can choose from 2 to 99 team runners. Confirm pressing enter.

When the first team racer will reach the finish line the respective starting signal will be initiated and the gate will be opened (assigned the red and the blue team).

The same procedure applies for the eventually following racers.

*To communicate the starting signal for your time measurement use the „output time measurement“ contact at the control unit.*

*To communicate the finish line signal (starting signal for the next runner) form your time measurement use the „Input start impulse“ contacts at the control unit. (see page -3-)*

Button F3 -> reset (race will be aborted, time offset will be reseted)

Button F4 -> home - back to main screen

## Setup touchscreen

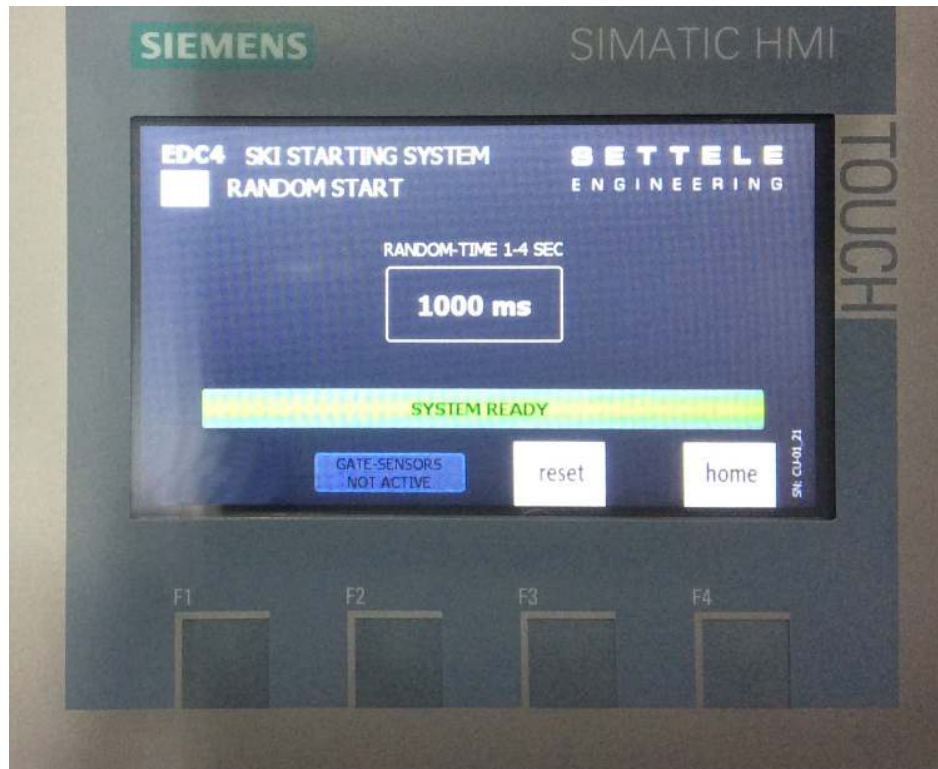

### 3. Random - Main screen

This race-event can be used for a parallel start on a random delay of 1 to 4 seconds. After the delay the gates open at the same time. The random delay is shown on the display after release.

Button F3 -> reset (race will be aborted, time offset will be reseted)

Button F4 -> home - back to main screen

Thank you very much and have fun with your new

**SETTELE SPORTSYSTEMS**  
**START GATE FIS EVO**



**SETTELE SPORTSYSTEMS**  
**Westpark 22**  
**D- 88161 Lindenberg (Germany)**  
**PHONE +49 (0) 8381 - 89169 50**  
**FAX +49 (0) 8381 - 89169 53**  
**E-MAIL [info@settele-engineering.de](mailto:info@settele-engineering.de)**  
**WEB [www.settele-sportsystems.com](http://www.settele-sportsystems.com)**